

## VectorPak™ T-Struts

Vector T-Struts can be used for custom assemblies or to fit existing cage assemblies. Available with two nut slots. As an alternative, mounting brackets (BR16A, available separately) may be used to attach struts to cages. Strut material is aluminum with clear irridite finish. Struts are attached to side panels with 10-32 screws (Part No. HD90).

### T-Strut Hardware Kit - HD34 or HD34B for Connector Mounting

HD34 (1/2" screws) and HD34B (1/4" screws) are complete edge-connector mounting kits for attachment to VectorPak™ 'T'-Struts.

Each kit contains:

42, 4-40 locking screws (SC4-28, 1/2"L or SC4-27, 1/4"L)

42, 4-40 locking nuts (NT4-7)

42 lockwashers

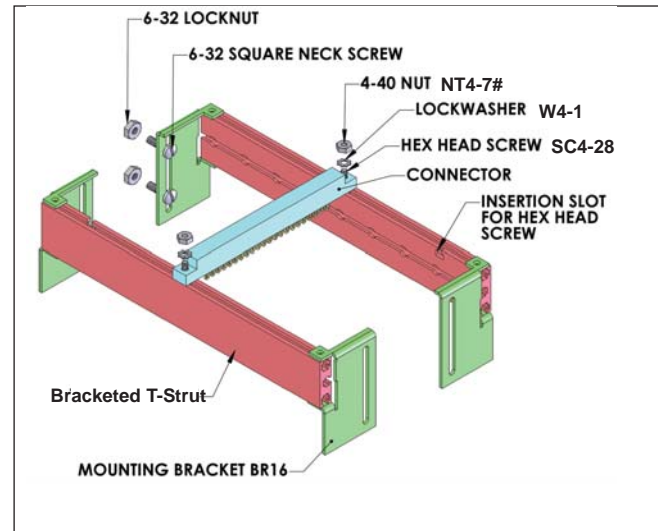
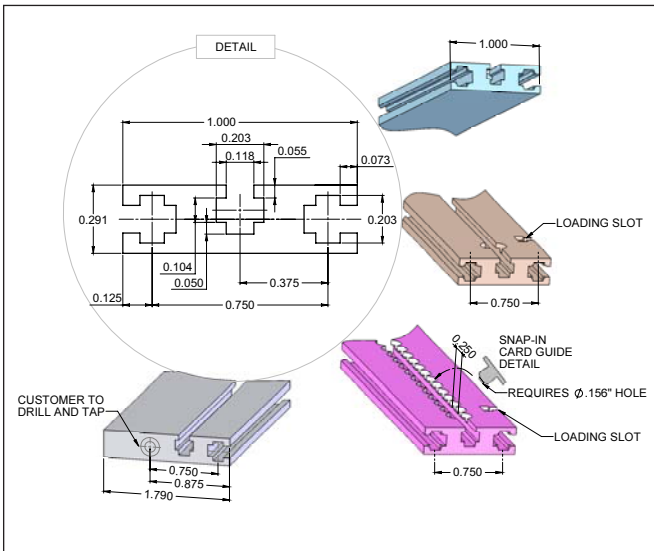

To mount connectors, simply slide nut into desired position and fasten with screws and lockwasher as illustrated. SC4-28 screws available in bulk quantities.

Figures showing T-Strut features - see table

**BR16A Bracket Kit** includes two each BR16-1 (right) and BR16-2 (left) brackets plus installation hardware. Bracket assemblies are normally used on rear strut, though front strut may use them as well. HD90 Self-tapping Screws (pkg. 12 not shown) may also be used to mount T-struts to sidewalls.

NT4-7PA: Pkg 25 nuts that load into "T-Strut" groove

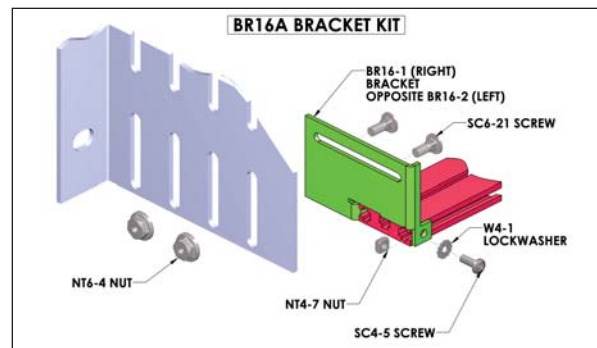

End Part No.	Length	Width	Method of Fastening	Fig.	Description
TS81	8.12"	1"	BR16 Brackets or HD90 Screws	1	1" wide T-strut, Pk. of 1 each
TS81-5/90	8.12"	1"	BR16 Brackets or HD90 Screws	4	1" wide T-strut, Pk. of 1 each
TS169	16.85"	1"	BR16 Brackets or HD90 Screws	1	1" wide T-strut, Pk. of 1 each
TSW169	16.85"	1.75"	HD90 Screws	5	1.75" wide T-strut, Pk. of 1 each
TS169-6/90	16.85"	1"	HD90 Screws	4	1" wide T-strut, Pk. of 1 each, dimpled for Snap-in guide insertion
TS209	20.85"	1"	BR16 Brackets or HD90 Screws	1	1" wide T-strut, Pk. of 1 each
TS300	30.00"	1"	Raw Stock	1	1" wide T-strut, Pk. of 1 each
TSW300	30.00"	1.75"	Raw Stock	5	1.75" wide T-strut, Pk. of 1 each
TS600	60.00"	1"	Raw Stock/pkg.	3	1" wide T-strut, Pk. of 4 pcs.

Custom lengths available on request

EIA Subracks



8 7 6 5 4 3 2 1

REVISIONS				
ZONE	REV.	DESCRIPTION	DATE	APPROVED
ALL	A	TABLE REDRAWN ECO 3290	12/10/86	
	B	REMOVED UNUSED P/N#	02/10/09	

DETAIL 1

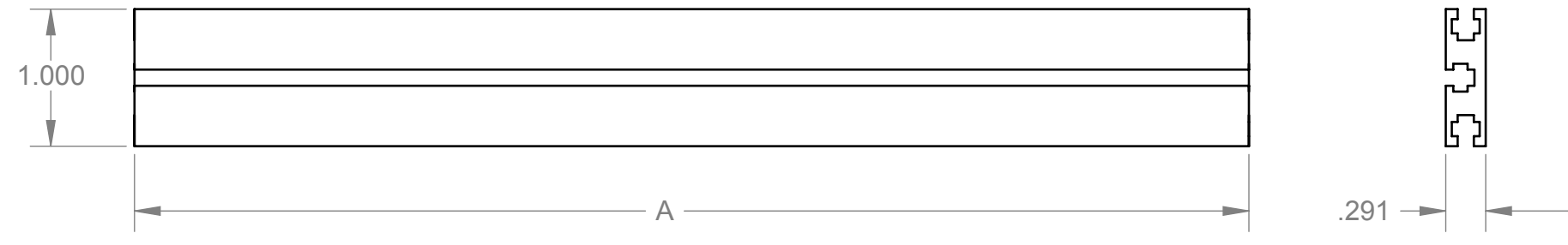

DETAIL 2

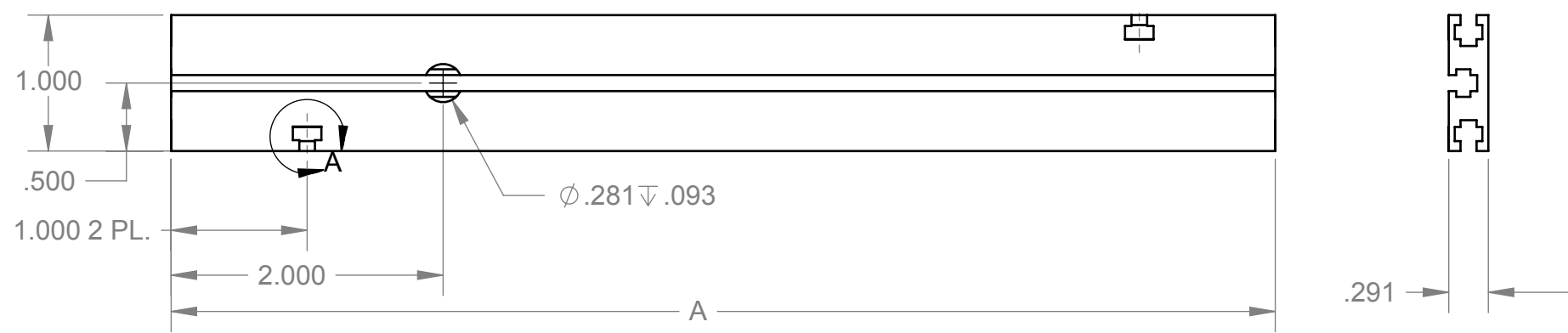

DETAIL 3

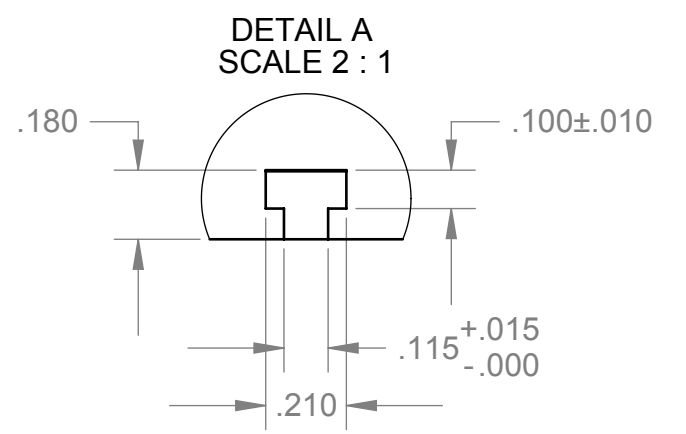
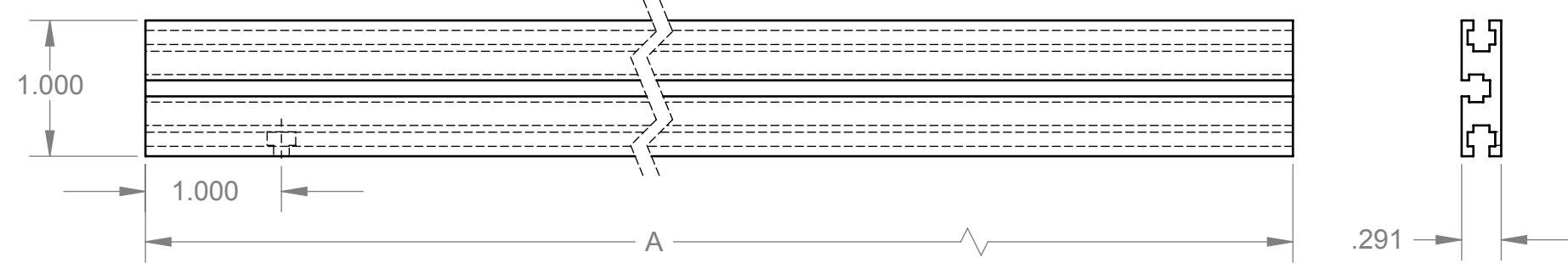

- 5. DEGREASE
- 4. STRAIGHT WITHIN .015/10" IN LENGTH
- 3. CUT ENDS TO BE SQUARE WITHIN .0025/INCH IN WIDTH
- 2. REMOVE ALL BURRS
- 1. MAT'L: AL. EXTRUSION, 6063-T6, PRE-ANOD., P/N TS100

NOTES: UNLESS OTHERWISE SPECIFIED.

**PROPRIETARY AND CONFIDENTIAL**  
 THE INFORMATION CONTAINED IN THIS DRAWING IS THE SOLE PROPERTY OF VECTOR ELECTRONICS & TECH., INC. ANY REPRODUCTION IN PART OR AS A WHOLE WITHOUT THE WRITTEN PERMISSION OF VECTOR ELECTRONICS & TECH., INC. IS PROHIBITED.

UNLESS OTHERWISE SPECIFIED:  
 DIMENSIONS ARE IN INCHES  
 TOLERANCES:  
 FRACTIONAL ±  
 ANGULAR: ± X°  
 TWO PLACE DECIMAL ±.03  
 THREE PLACE DECIMAL ±.005  
 INTERPRET GEOMETRIC TOLERANCING PER:  
 MATERIAL **1**  
 FINISH   
 DO NOT SCALE DRAWING

	NAME	DATE
DRAWN	TRUSHAR	02/06/09
CHECKED		
ENG APPR.		
MFG APPR.		
Q.A.		

THIRD ANGLE PROJECTION

11115 VANOWEN ST.,  
 NORTH HOLLYWOOD,  
 CA 91605

## T-STRUT W/O INSERTS

SIZE	DWG. NO.	REV
<b>B</b>	<b>5280006</b>	<b>B</b>
SCALE: 1:1	WEIGHT:	SHEET 1 OF 1

8 7 6 5 4 3 2 1

INSPECTION REQUIREMENTS	
1	CHECK OVERALL LENGTH
2	CHECK "C" DIMENSION
3	VERIFY .156 DIA. WILL FIT INTO PUNCHED RADII & .160 DIA. WILL NOT FIT INTO PUNCHED RADII
4	CHECK "B" DIMENSION
5	NO CHIPS IN THE BOTTOM OF SLOT

REVISIONS				
ZONE	REV.	DESCRIPTION	DATE	APPROVED
ALL	-	RELEASED FOR PROTOTYPE 100 UNITS OF CCK13S 50 CCM14S & 50 CCK13S	02/14/80	
	A1	P/N TS81-5 NO. OF HOLES WAS 30 ACTUAL STOCK PARTS HAVE 31	07/31/80	
	B	P/N TS81-5 "B" DIM. WAS 7.500 NO. OF HOLES WERE 31/ ECO2013	03/26/81	
	C	MOVED 1.000 DIM. LOCATION CALLOUT FOR CLARITY NO ECO		
	D	ADDED TS81-6 & -7		
	D	INC ECO 2628	12/17/84	
	E	INC ECO 3924		
	F	REMOVED P/N# TS81-6, -7 TS169-6, TS209-5	02/10/09	

D

C

B

A

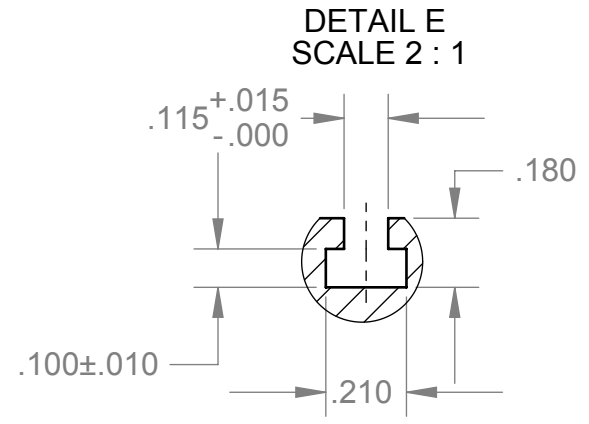
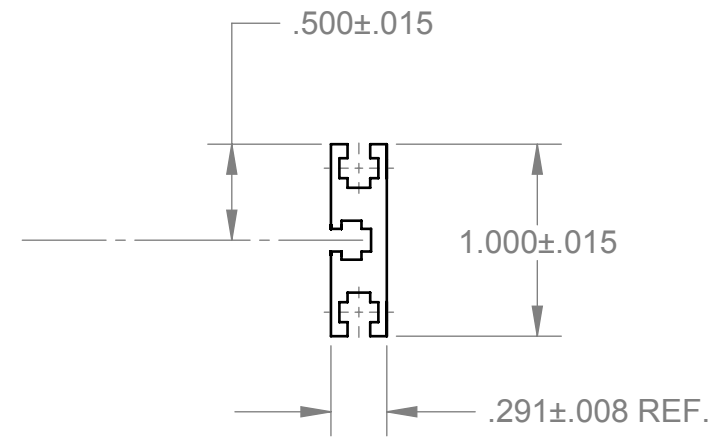
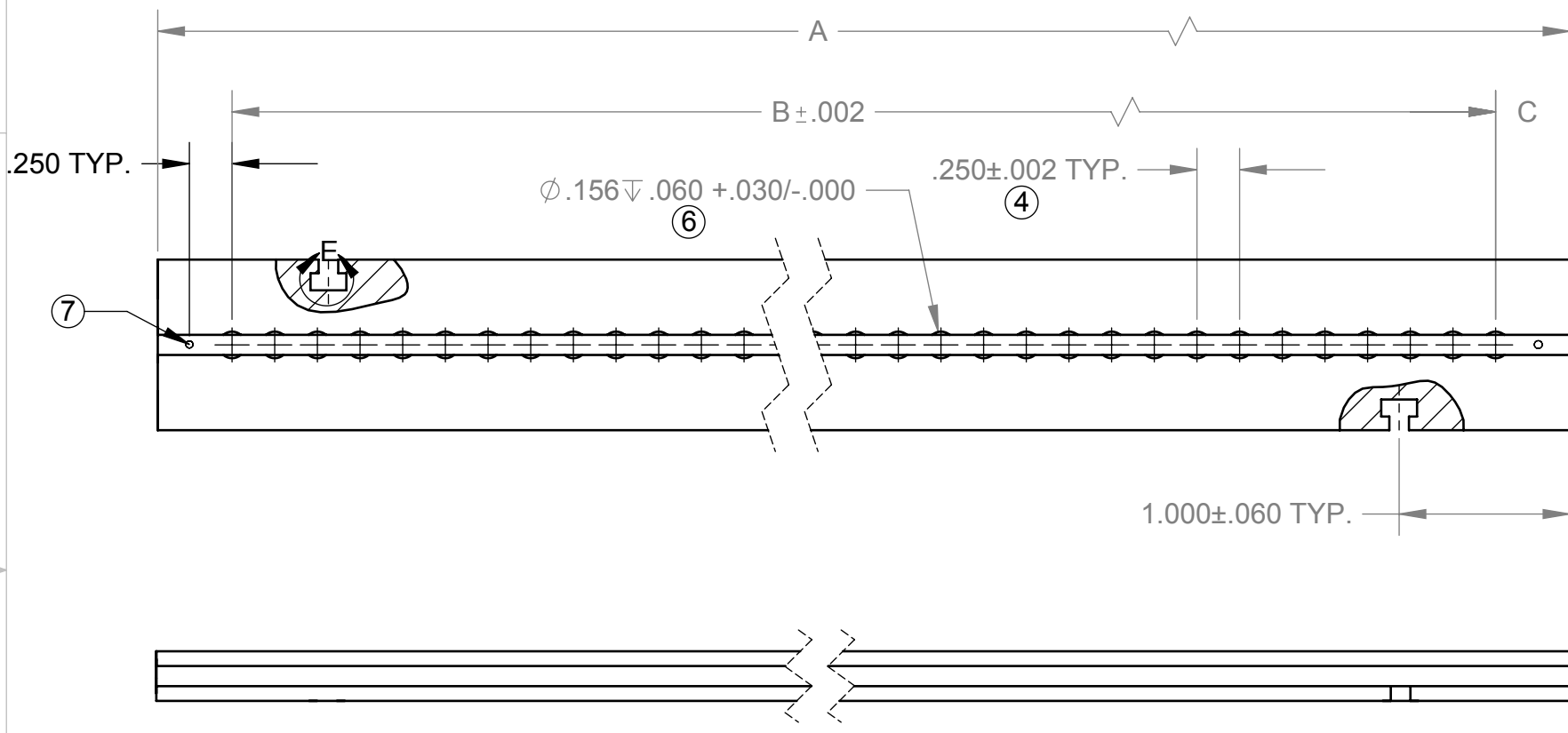

PART NO.	A	B	C	NO. OF HOLES
TS81-5/90	8.120	7.250	.435	30
TS169-6/90	16.850	15.750	.675	64

- ⑦ TOOLING MARK MAY APPEAR
- ⑥ USE .1565 DIA. PUNCH TO FORM RADIUS EQUAL WITHIN ±.005 FROM C<sub>L</sub> OF SLOT
- 5. PART TO BE FREE OF BURRS AND SURFACE SCRATCHES
- ④ NON CUMULATIVE TOLERANCE
- 3. PART TO BE STRAIGHT WITHIN .015/10 INCHES IN LENGTH
- 2. CUT ENDS TO BE SQUARE WITHIN .0025/INCH IN WIDTH
- 1. MAT'L: AL. EXTRUSION, 6063-T6, PRE-ANOD., P/N TS100

NOTES: UNLESS OTHERWISE SPECIFIED.

**PROPRIETARY AND CONFIDENTIAL**  
THE INFORMATION CONTAINED IN THIS DRAWING IS THE SOLE PROPERTY OF VECTOR ELECTRONICS & TECH., INC. ANY REPRODUCTION IN PART OR AS A WHOLE WITHOUT THE WRITTEN PERMISSION OF VECTOR ELECTRONICS & TECH., INC. IS PROHIBITED.

UNLESS OTHERWISE SPECIFIED:		NAME	DATE
DIMENSIONS ARE IN INCHES	DRAWN	TRUSHAR	02/10/09
TOLERANCES:	CHECKED		
FRACTIONAL ±	ENG APPR.		
ANGULAR: ± X°	MFG APPR.		
TWO PLACE DECIMAL ±.03	Q.A.		
THREE PLACE DECIMAL ±.005			
INTERPRET GEOMETRIC TOLERANCING PER:			
MATERIAL ①	THIRD ANGLE PROJECTION		
FINISH □			
DO NOT SCALE DRAWING			

**VECTOR** 11115 VANOWEN ST., NORTH HOLLYWOOD, CA 91605

**T-STRUT FOR SNAP-IN CARD GUIDE**

SIZE	DWG. NO.	REV
B	M6336D4.2	F
SCALE: 1:1	WEIGHT:	SHEET 1 OF 1

REVISIONS				
ZONE	REV.	DESCRIPTION	DATE	APPROVED
ALL	C	ADDED DET. NO. 4 ECO 1481 ADDED P/N TSW169-4	06/05/74	
	C1	ADDED CAT NO. TSW-81N-4	09/22/74	
	C2	DIM .875 WAS .825		
	D	REV'D Ø.281 HOLE POS. ECO 1682		
	D1	ADDED Z4424-30-4 & -5 TO TABLE		
	E	ECO 1926	01/07/80	
	E1	P/N M4424-30-1 WAS DETAIL 3 & INSERT WAS NONE (ERROR)	12/08/81	
	E2	DELETED P/N M4424-30-1	12/15/81	
	F	INC ECO 3924		
	F1	DETAIL 4 HOLE SIZE WAS Ø.1875 +.003/-.000 x .312 +.020/-.000 DEEP		
	F2	INC ECO 3949		
	F3	ADDED NOTE 10		
	F4	REMOVED NO LONGER USED P/N#	02/10/09	

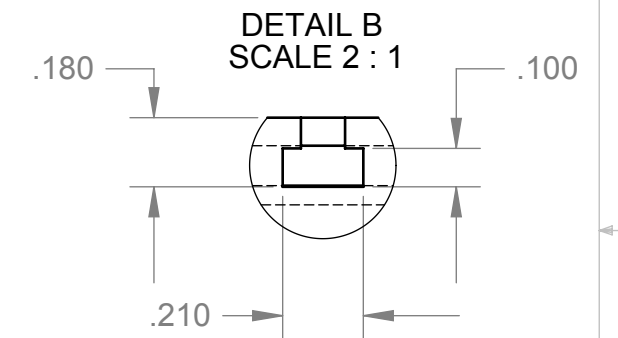
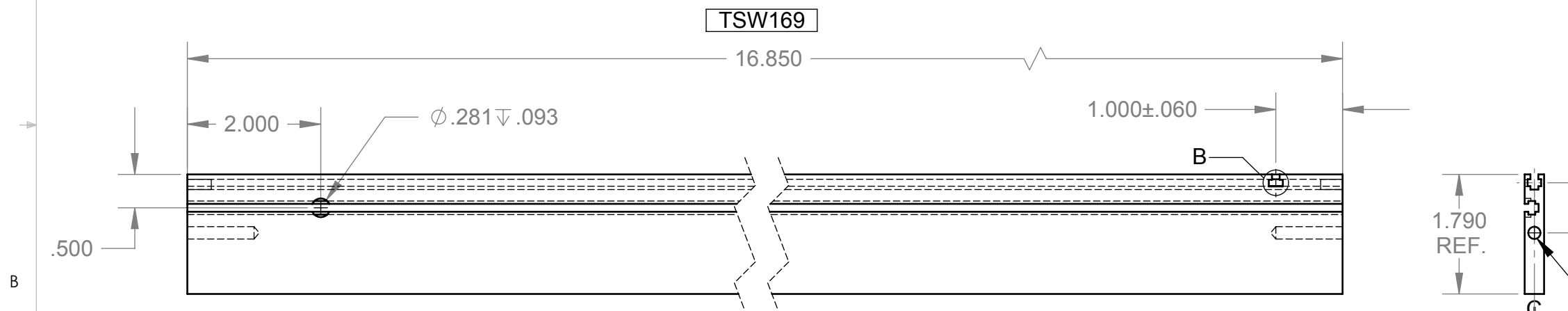
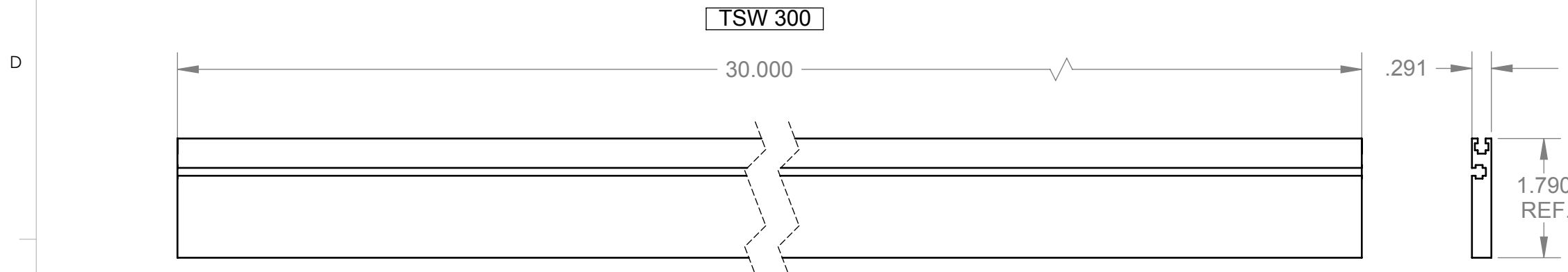

#13 DRILL Ø.185 x  
1.000 +.020/-.000 DEEP  
2 PLACES

6. USE SQUARE ENDED CLOSE FITTING GAUGE PIN TO CHECK DEPTH OF HOLE  
 5. PARTS TO BE DEGREASED AFTER FABRICATION  
 4. PARTS TO BE FREE OF BURRS & SURFACE SCRATCHES REMOVE ALL BURRS FROM EXTRUDED T-SLOTS  
 3. PART TO BE STRAIGHT WITHIN .015/10 INCHES IN LENGTH  
 2. CUT ENDS TO BE SQUARE WITHIN .0025/INCH IN WIDTH  
 1. MAT'L: AL. EXTRUSION, 6063-T6

NOTES: UNLESS OTHERWISE SPECIFIED.

**PROPRIETARY AND CONFIDENTIAL**  
 THE INFORMATION CONTAINED IN THIS DRAWING IS THE SOLE PROPERTY OF VECTOR ELECTRONICS & TECH., INC. ANY REPRODUCTION IN PART OR AS A WHOLE WITHOUT THE WRITTEN PERMISSION OF VECTOR ELECTRONICS & TECH., INC. IS PROHIBITED.

UNLESS OTHERWISE SPECIFIED:		NAME	DATE
DIMENSIONS ARE IN INCHES	DRAWN	TRUSHAR	02/10/09
TOLERANCES:	CHECKED		
FRACTIONAL ±	ENG APPR.		
ANGULAR: ± X°	MFG APPR.		
TWO PLACE DECIMAL ±.03	Q.A.		
THREE PLACE DECIMAL ±.005			
INTERPRET GEOMETRIC TOLERANCING PER:			
MATERIAL <b>1</b>	THIRD ANGLE PROJECTION		
FINISH <input type="checkbox"/>			
DO NOT SCALE DRAWING			

**VECTOR** 11115 VANOWEN ST.,  
ELECTRONICS & TECHNOLOGY, INC. NORTH HOLLYWOOD, CA 91605

**T-STRUT DETAIL  
TSW-SER.**

SIZE	DWG. NO.	REV
B	M4424D5.30	F
SCALE: 1:2	WEIGHT:	SHEET 1 OF 1